

2-PC Casting Ball Valve Full Port, Direct Mount, 2000-1500 WOG, High Performance

KV-L20H (Direct Mount Type)
KV-L20HF (Direct Mount Type / Fire Safe Type)

FEATURES:

- **Fire Safe** Design Approved
- Built-in ISO 5211 Direct Mounting Pad and Square Stem for Easy Automation
- Anti-Static Devices for Ball-stem-body
- Blow-out Proof Stem
- Pressure Balance Hole in Ball Slot
- Pre-load 2 Belleville Washers to Self-adjust Packing
- **TA-LUFT** Design Approved
- Options: 1. Actuator 2. Limit Switch 3. Positioner

STANDARDS:

- Design: MSS SP-110
2000 WOG for 1/4" ~ 1"
1500 WOG for 1-1/4" ~ 3"
- Wall Thickness: EN 12516-3
- Pipe Thread: ASME B1.20.1
DIN 2999 / 259, ISO 228 / 1
JIS B 0203, ISO 7 / 1
- Inspection & Testing: MSS SP-110

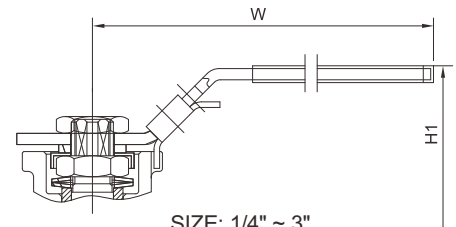
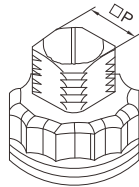
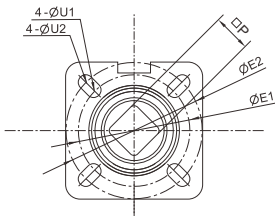

SIZE: 1/4" ~ 3"

NO.	PART NAME	MATERIALS		
1	Body	CF8M	CF8	WCB
2	End Cap	CF8M	CF8	WCB
3	Ball Seat	TFM4215		
4	Ball	CF8M	CF8	
5	Stem	316	304	
6	Anti-Static Device	316	304	
7	Thrust Washer	PTFE		
8	O-Ring	FKM		
9	Stem Packing	PTFE/GRAFOIL*		
10	Bushing	50%SS + 50%PTFE / 304*		
11	Gland	316		
12	Belleville Washer	301		
13	Stem Nut	A194-8		
14	Stop-Lock-Cap	304		
15	Hex Bolting	A193-B8		
16	Body Gasket	PTFE /GRAFOIL*		
17	Actuator	Pneumatic KP / Electric KQ		

*Materials for FIRE-SAFE Models

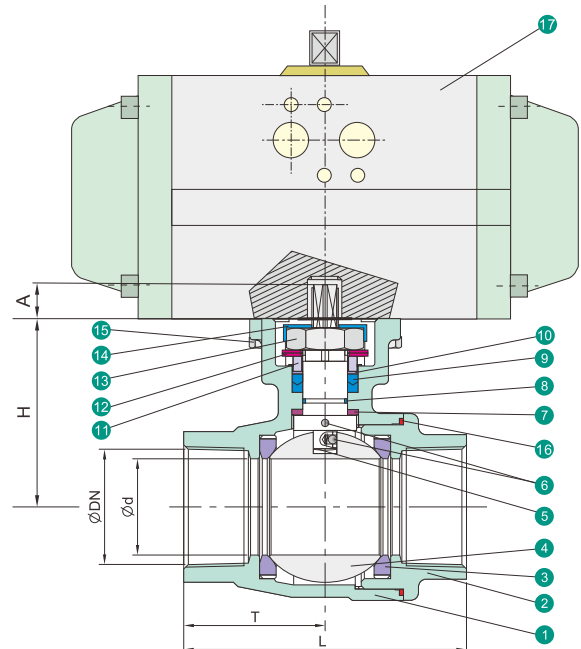

Unit: mm

SIZE	d	L	H	H1	W	E1	E2	T	U1	U2	A	P	HEX.B	ISO 5211
1/4"	10.6	62.0	135.0	43.1	145.0	36	42	29.0	6	6	9	9	23.5	F03-F04
3/8"	12.0	62.0	135.0	43.1	145.0	36	42	29.0	6	6	9	9	23.5	F03-F04
1/2"	15.0	75.0	135.0	43.1	145.0	36	42	34.5	6	6	9	9	28.0	F03-F04
3/4"	20.0	80.0	135.0	50.7	145.0	36	50	37.0	6	7	9	9	33.0	F03-F05
1"	25.0	90.0	170.0	58.0	175.0	42	50	45.0	6	7	11	11	45.0	F04-F05
1-1/4"	32.0	110.0	170.0	63.0	175.0	42	70	51.0	6	9	11	11	51.0	F04-F07
1-1/2"	38.0	120.0	200.0	74.0	190.0	50	70	60.0	7	9	14	14	59.0	F05-F07
2"	50.0	140.0	200.0	83.5	190.0	50	70	70.0	7	9	14	14	73.0	F05-F07
2-1/2"	63.5	185.0	200.0	102.3	265.0	70	102	92.5	9	11	17	17	90.0	F07-F10
3"	76.0	205.0	200.0	110.7	300.0	70	102	102.5	9	11	17	17	104.0	F07-F10